

## Standard Cladding Board

<b>Composition:</b>	<ul style="list-style-type: none"> <li>• 55% – wood flour</li> <li>• 35% – high-density polyethylene (HDPE)</li> <li>• 10% – anti-UV additives, stabilizers, colourants</li> </ul>
<b>Dimensions:</b>	<ul style="list-style-type: none"> <li>• thickness – 20 mm (<math>\pm 0,5</math> mm)</li> <li>• width – 165 mm (<math>\pm 1,0</math> mm)</li> <li>• length – 2,8-3,2 m</li> <li>• weight – 1,65 kg/m (-5%/+10%)</li> </ul>
<b>Properties:</b>	<ul style="list-style-type: none"> <li>• Fire resistance class: E (according to PN-EN 13501 standard) – the ability to withstand the impact of fire from one side only without transferring the fire to the unexposed side due to the penetration of flames or hot gases.</li> <li>• use in temperatures -30 °C/+60 °C</li> <li>• low water absorption &lt;0.7% (frost-resistant)</li> <li>• high resistance to UV</li> <li>• high resistance to cracking (excluding cracks caused by shock load)</li> <li>• high resistance to rotting and decay resulting from the direct action of fungi and bacteria</li> <li>• high resistance to damage caused by the direct impact of insects</li> </ul>
<b>Usage:</b>	<ul style="list-style-type: none"> <li>• facades</li> <li>• wall development</li> <li>• garden architecture</li> </ul>

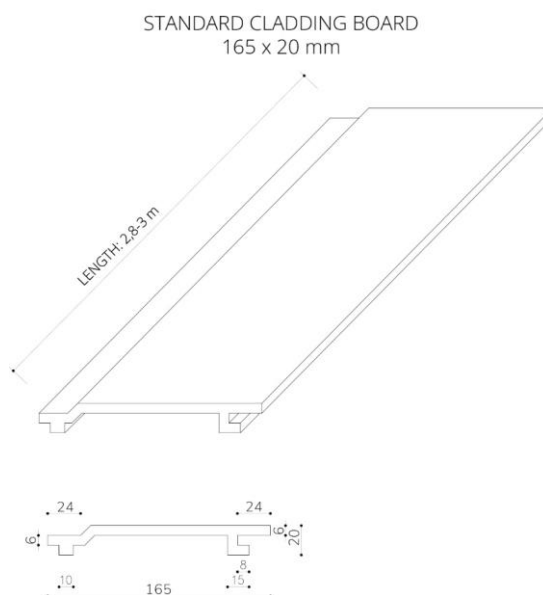

### Available colours:



EcoTravers cladding boards should not be installed in closed, damp and unventilated rooms, as well as in places with rapid and significant temperature changes (e.g. sauna).

**Before installation read the instructions on [www.liderwood.com](http://www.liderwood.com).**

During the first exploitation period the composite boards age under the influence of external conditions. The color stabilizes after a few months, reaching its final saturation. EcoTravers composite products may deviate from the available descriptions and samples in terms of natural color or structure differences. The boards may be subject to slight deformation (~1.5%).

### Available documents:

- Guarantee certificate
- Installation instructions
- Declaration of performance 13/03/2024 LD
- Sanitary certificate B-BK-602110056/20 dated 12.03.2020
- Fire Resistance Tests